



GRP5.12-WLV



GRP5.12-WLV Operation Manual

CONTENTS

1	Technical Data	1-2
2	Product Overview	3
2.1	Brief Introduction	3
2.2	Interface Introduction	4
2.2.1	Switch ON/OFF	4-5
2.2.2	LED Indicator Definition	5-6
2.2.3	CAN / RS485 Port	6
2.2.4	RS232 Port	6
3	Installation Guide	7
3.1	Checking Before Installation	7
3.1.1	Checking Outer Packing Materials	7
3.1.2	Checking Deliverables	7-8
3.2	Tools	9
3.3	Installation requirements	9
3.3.1	Installation environment requirements	9
3.3.2	Installation carrier requirements	9
3.4	Installation Instructions	10
3.4.1	Dimensions	10
3.4.2	Installation Procedure	11-14
4	Maintenance	15
4.1	Recharge Requirements During Normal Storage	15
4.2	Recharge Requirements When Over Discharged	16

01

TECHNICAL DATA

NOTE

Operating current derating according to cell voltage and battery temperature.



Performance	
Nominal Voltage	51.2 Vdc
Nominal Capacity	100Ah
Battery Energy	5120 Wh
Charge Voltage	56.16Vdc
Discharge Voltage	44.8 Vdc
Nominal Charge / Discharge Current	50A
Nominal Charge / Discharge Power	2560W
Max Charge / Discharge Current	100A
Max Charge / Discharge Power	5120W
Short Circuit Current	350A/3mS
Communication	
Display	SOC status indicator, LED indicator
Communication	RS232、RS485、CAN
General Specification	
Dimension(WxDxHmm)	520x470x141.5mm
Weight (Kg)	47.2kg
Installation	Floor stand or Wall mounted
Charging Temperature Range	0°C ~ 55°C
Discharge Temperature Range	-20°C ~ 60°C
Operating / Storage / humidity	≤95%RH
Max Operating Altitude	≤2000m
IP Rating	IP65
Cell Technology	LiFePO ₄ , Lithium Iron Phosphate
Cycle life	6000 Cycles @ 80% DOD / 25°C / 0.5C. 60%EOL
Scalability	Max 15 batteries in parallel
Standard Compliance	
Certification	CB,IEC62619; GPSD EN62619; CE-EMC, EN61000-6-1/2/3/4UN38.3;MSDS;RoHS

1. Test conditions: 100% depth of discharge (DoD), 0.2C rate charge & discharge at 25°C.

2. Charge/discharge derating occurs when the operating temperature from -10°C to 5°C& 45°C to 55°C.

3. Condition apply, Refer to GRP5.12-WLV Warranty Letter.

PRODUCT OVERVIEW

2.1 Brief Introduction

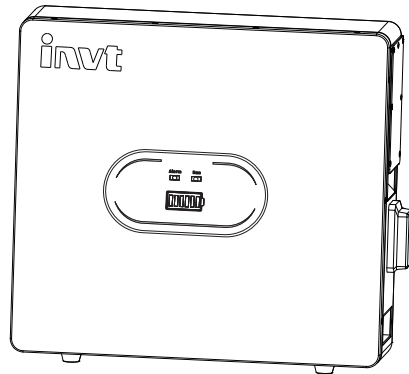

PRODUCT OVERVIEW

GRP5.12-WLV is a lithium battery with an operating voltage range between 45.6~56.16V. It is designed for residential energy storage applications and works together with a 48v battery hybrid inverter. **GRP5.12-WLV is not suitable for supporting life-sustaining medical devices.**

GRP5.12-WLV has built-in BMS (Battery Management System), which can manage and monitor cells information including voltage, current and temperature. Besides that, BMS can balance cells charging to extend cycle life. BMS has protection functions including over-discharge, over-charge, over-current and high/low temperature; the system can automatically manage charge state, discharge state and balance state.

Multiple GRP5.12-WLV can be connected in parallel to expand capacity and power, 15 GRP5.12-WLV can be connected in parallel at most.

2.2 Interface Introduction

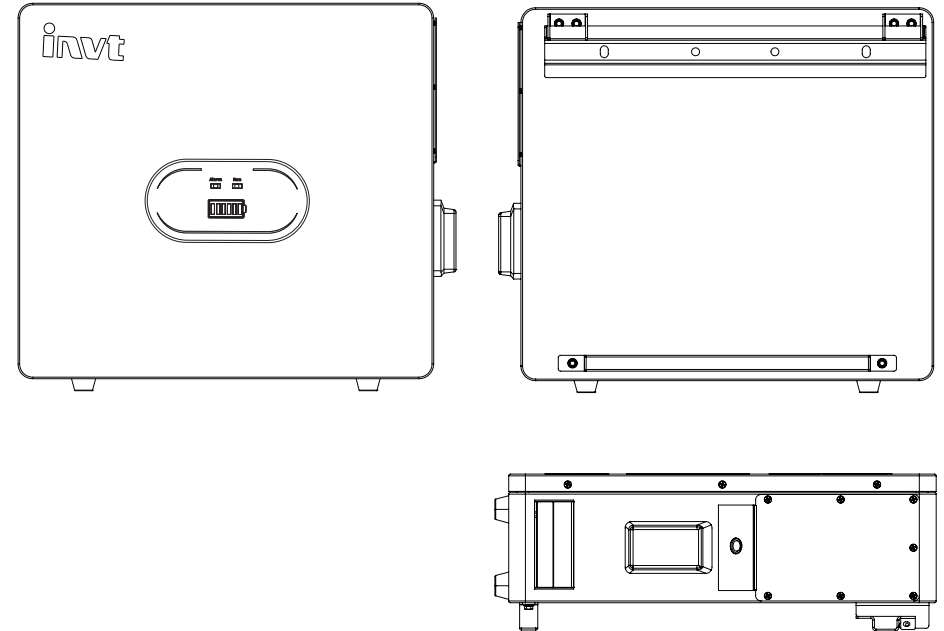

2.2.1 Switch ON/OFF

1. Switch ON

Turn on a single GRP5.12-WLV, turn on the air switch, then press the circular weak current switch (more than 3 seconds) on / off button, the LED flashes and the battery works normally. L1 to L6 display the battery SOC, L7/L8 to indicate the battery status.

For multiple GRP5.12-WLV in parallel, switch ON circular weak current switch on all batteries, long press (more than 3 seconds) ON/OFF button of MASTER battery, LED will flash. battery system will automatically encode and assign ID to each slave battery, then battery system will operate normally.

2. Switch OFF

Press the Circular weak current switch of the master pack for more than 3 seconds and then release the button. When all slave pack are closed, the master pack will be closed (sleep mode). For a single **GRP5.12-WLV**, turn off the Circular weak current switch. For multiple **GRP5.12-WLV** in parallel, turn off the Circular weak current switch on the main battery first. Then turn off the Circular weak current switch on all subordinate batteries

2.2.2 LED Indicator Definition

Note:

flash 1 - 0.25s light / 3.75s off

flash 2 - 0.5s light / 0.5s off

flash 3 - 0.5s light / 1.5s off

LED Indicators Instructions

Status	RUN	ALM	Battery Level Indicator							Descriptions
	L8	L7	L6	L5	L4	L3	L2	L1		
Shut down	OFF	OFF	OFF	OFF	OFF	OFF	OFF	OFF	OFF	All OFF
Standby	Flash 1	OFF	According to the battery level							Indicates Standby
Charging	Normal	Light	According to the battery level							The highest capacity indicator LED flashes(flash 2) others lighting
	Full Charged	Light	OFF	Light	Light	Light	Light	Light	Light	Turn to standby status when charger off
	Protection	OFF	Light	OFF	OFF	OFF	OFF	OFF	OFF	Stop charging
Discharg	Normal	Flash 3	According to the battery level							
	UVP	OFF	OFF	OFF	OFF	OFF	OFF	OFF	OFF	Stop charging
	Protection	OFF	Light	OFF	OFF	OFF	OFF	OFF	OFF	Stop discharging
Fault	OFF	Light	OFF	OFF	OFF	OFF	OFF	OFF	OFF	Stop charging and Discharging

Charging Battery Level Indicators Instructions

Status	Charging								
	L8	L7	L6	L5	L4	L3	L2	L1	
Battery Level Indicator									
Battery Level (%)	0 ~ 17%	Light	OFF	OFF	OFF	OFF	OFF	Flash 2	
	18 ~ 33%			OFF	OFF	OFF	OFF	Flash 2	Light
	34 ~ 50%			OFF	OFF	OFF	Flash 2	Light	Light
	51 ~ 66%			OFF	OFF	Flash 2	Light	Light	Light
	67 ~ 83%			OFF	Flash 2	Light	Light	Light	Light
	84 ~ 100%			Flash 2	Light	Light	Light	Light	Light
	Full Charged			Light	Light	Light	Light	Light	Light

Discharging Battery Level Indicators Instructions

Status	Discharge							
	L8	L7	L6	L5	L4	L3	L2	L1
Battery Level Indicator								
Battery Level (%)	Flash 3	OFF	OFF	OFF	OFF	OFF	OFF	Light
			OFF	OFF	OFF	OFF	Light	Light
			OFF	OFF	OFF	Light	Light	Light
			OFF	Light	Light	Light	Light	Light
			Light	Light	Light	Light	Light	Light
			Light	Light	Light	Light	Light	Light

2.2.3 CAN / RS485 Port

CAN / RS485 Communication Terminal (RJ45 port), connect to inverter, follow CAN / RS485 protocol.

PIN	Definition
Pin 1、Pin 8	RS485-B (to PCS, reserved)
Pin 2、Pin 7	RS485-A (to PCS, reserved)
Pin 3	NC
Pin 4	CANH (to PCS)
Pin 5	CANL (to PCS)
Pin 6	GND

2.2.4 RS232 Port

RS232 Communication Terminal (RJ45 port) follow RS232 protocol, for manufacturer or professional engineer to debug or service.

PIN	Definition
Pin 1、Pin 8	GND
Pin 2、Pin 7	RS232_TX
Pin 3、Pin 6	RS232_RX
Pin 4、Pin 5	NC

03

INSTALLATION GUIDE

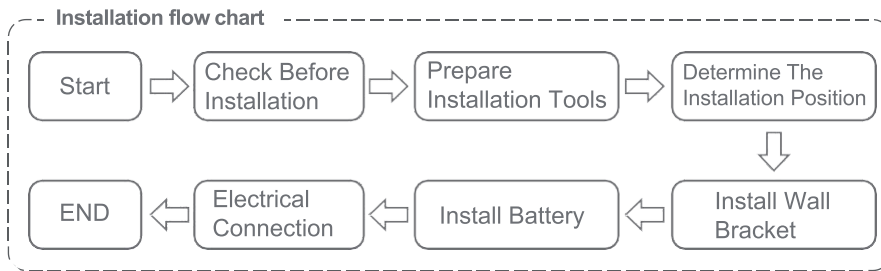
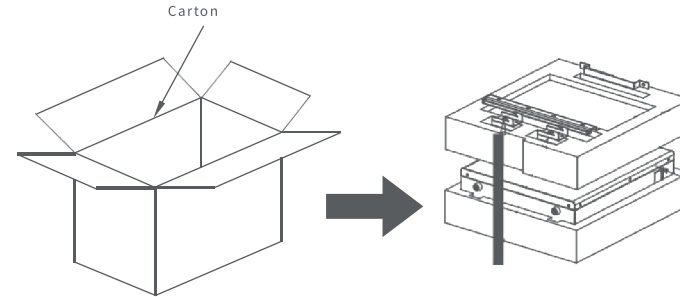

No.	Pictures of accessories	Quantit	Uses
1		1	Battery box
2		1	Wall mounting bracket
3		2	Hanging bracket
4		1	Bottom support bracket
5		1	Parallel terminals
6		1	Parallel terminals
7		1	Power Line
8		1	Connet cable

No.	Pictures of accessories	Quantit	Uses
9		4	Lock Wall Pendant
10		10	Ground screw
11		4	RJ45 Crystal head
12		2	Communication network cable
13		2	Desiccant
14		1	User manual
15		1	Outgoing Inspection Report

3.1 Checking Before Installation

3.1.1 Checking Outer Packing Materials

Packing materials and components may be damaged during transportation. Therefore, check the outer packing materials before installing the battery. Checking the surface of packing materials for damage, such as holes and cracks. If any damage is found, do not unpack the battery and contact the dealer as soon as possible. You are advised to remove the packing materials within 24 hours before installing the battery.

3.1.2 Checking Deliverables

After unpacking the battery, check whether deliverables are intact and complete. If any damage is found or any component is missed, contact the dealer. The below table shows the components and mechanical parts that should be delivered.

3.2 Tools

Tools			
Installation	Knife 	Measuring tape 	Socket wrench (10/16mm) 
	Rubber mallet 	Cross Screwdriver 	Hammer drill (10mm) 
Protection	ESD gloves 	Safety goggles 	Anti-dust respirator 
	Safety shoes 		

3.3 Installation requirements

3.3.1 Installation environment requirements

- Install the battery in the indoor environment.
- Place battery in secure location away from children and animals.
- Do not place the battery near any heat sources and avoid sparks.
- Do not expose the battery to moisture or liquids.
- Do not expose the battery to direct sunlight.

3.3.2 Installation carrier requirements

- Only mount battery on fire resistant building. Do not install batteries on flammable buildings.
- Battery is quite heavy, make sure the wall/ground can meet the load bearing requirements.

3.4 Installation Instructions

3.4.1 Dimensions

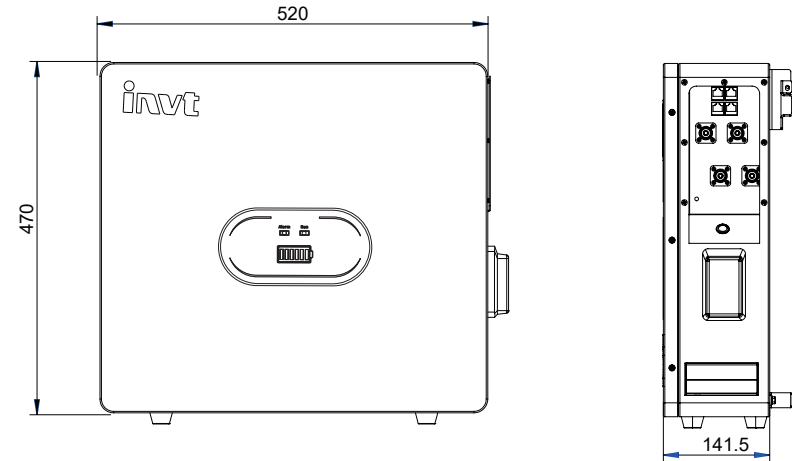

Minimum mounting distance between battery pack and equipment:

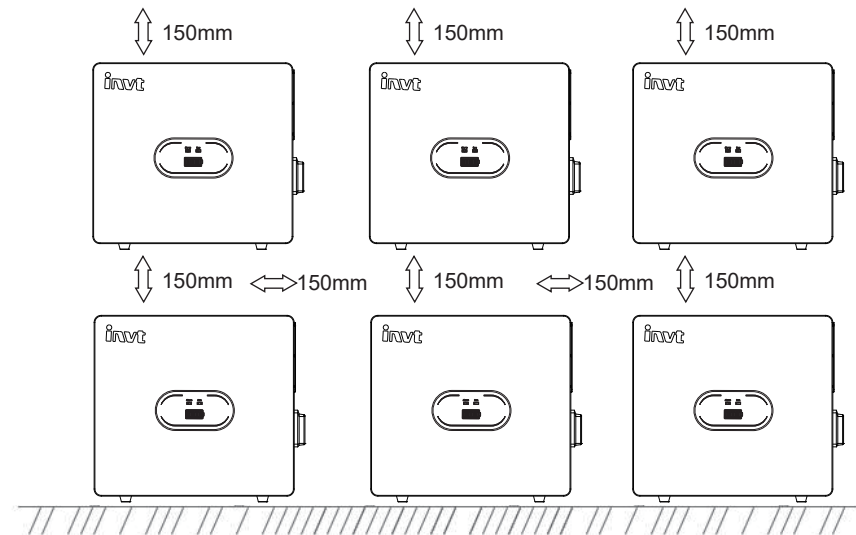

3.4.2 Installation Procedure

STEP 1

Drill the hole with an 10mm drill bit as follows and fix the wall bracket to the wall.

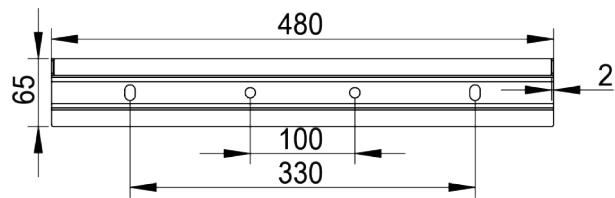

STEP 2

Install the hanging bracket.

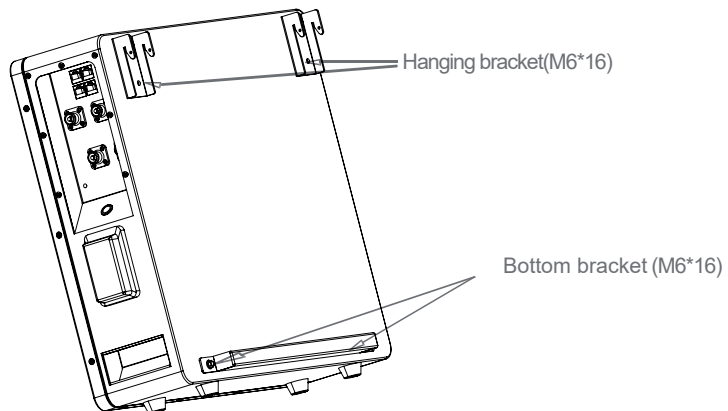

STEP 3

Hang GRP5.12-WLV on the wall bracket and tighten it.

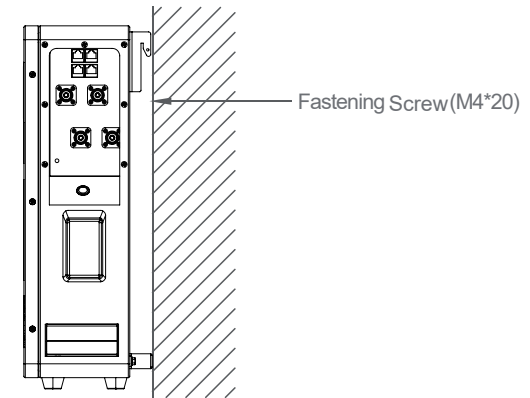

STEP 4

Connect to ground.

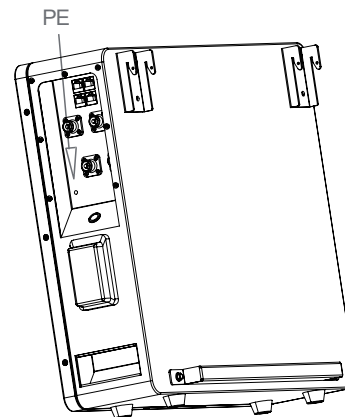

STEP 5

Connect power cable.

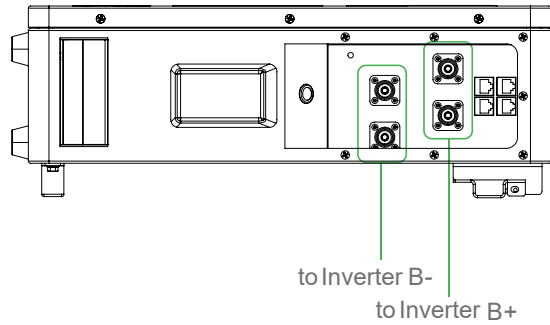

STEP 6

Connect communication cable.

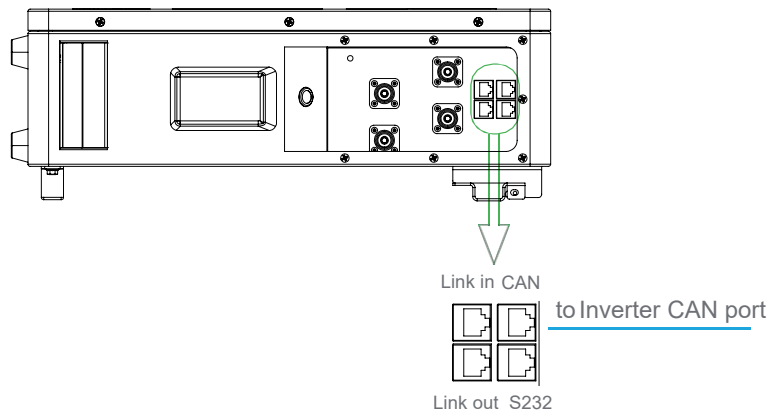

STEP 7

When multiple batteries are connected in parallel, follow the following wiring mode.

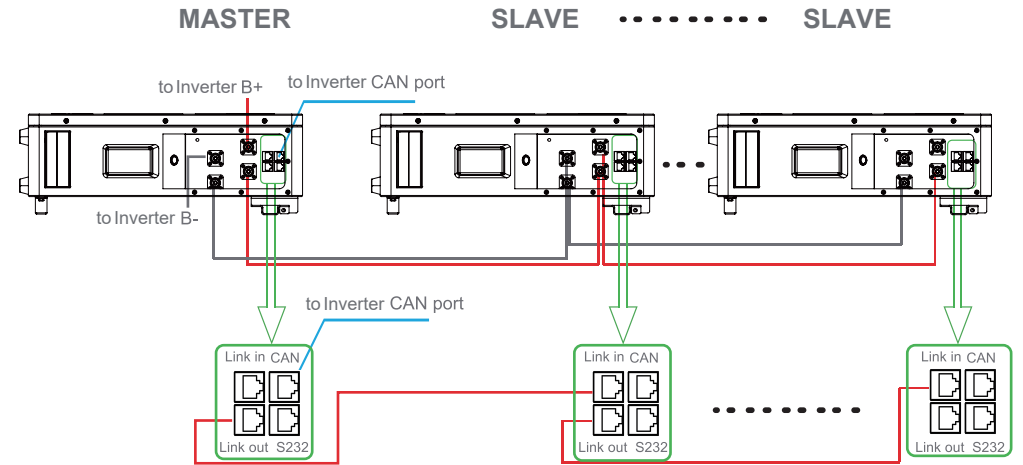

04

MAINTENANCE

4.1 Recharge Requirements During Normal Storage

Battery should be stored in an environment with temperature range between -10°C ~+45°C, and maintained regularly according to following table with 0.5C (25A) current till 40% SOC after long storage time.

Recharge Conditions When In Storage

Storage Environment Temperature	Relative Humidity of Storage Environment	Storage Time	SOC
Below -10°C	/	prohibit	/
-10~25°C	5%~70%	≤12 months	30%≤SOC≤60%
25~35°C	5%~70%	≤6 months	30%≤SOC≤60%
35~45°C	5%~70%	≤3 months	30%≤SOC≤60%
Above 45°C	/	prohibit	/

4.2 Recharge Requirements When Over Discharged

Over discharged (90% DOD) battery should be recharged according to following table, otherwise over discharged battery will be damaged.

Recharge conditions when battery is over discharged

Storage Environment Temperature	Storage Time	Note
-10~25°C	≤15 days	Battery Pack disconnected from to Inverter
25~35°C	≤7 days	
35~45°C	<12 hours	Battery Pack connected to Inverter